



Service & Installation Instructions

Keep this booklet for Future Reference

- **CWC SERIES**
- **CW SERIES**
- **HW SERIES**
- **SB SERIES**
- **SBI SERIES**

For Additional Copies Please Contact:

Hillphoenix Barker Specialty Products
703 Franklin Street
P.O. Box 478
Keosauqua, Iowa 52565
Tel: 319/ 293-3777
Fax: 319/ 293-3776

Or Visit:
www.hillphoenix.com

Table of Contents

General Information

Case Descriptions -----3
Shipping Information -----3
Cold Well Sections -----4
Cold Well Mechanical View -----5
Hot Well Section -----5

Installation Instructions

Location -----6
Crate Removal -----6
Case Exterior Loading -----6
Leveling -----6
Compressor -----6
Drain Electrical and Refrigeration Connections
for Remote Cases -----6
Glass Adjustment -----7
Cart Bumper Installation -----7

Refrigeration Information

Case Operation for Self Contained -----9
Typical Component Settings -----9
Refrigeration Loads -----9
Electronic Thermostat -----9

Electrical Information

Amperage Information -----10
Wiring Color Code -----10
Timers -----10
Ballast Wiring -----11
Hot Well Operation -----12

Maintenance Information

Cleaning -----13
Light Replacement -----13

Service

Preventative Maintenance -----14
Hot Well Troubleshooting Guide -----14
Cold Well Troubleshooting Guide -----15
Service Department -----16
Parts -----16

Warranty -----17

IMPORTANT!!
KEEP FOR FUTURE REFERENCE

General Information

This booklet contains information on:

CWC

Cash Wrap Counter

CW Series

Cold Well Merchandiser

HW Series

Hot Well Merchandiser

SB1 Series

Single Sided Salad Bar

SB2 Series

Two Sided Salad Bar

The CW Series conform to the following standards



The HW Series conform to the following standards



The SB1 and SB2 Series conform to the following standards



Shipping Information

IMPORTANT!

FOR YOUR PROTECTION PLEASE READ AND OBSERVE THE FOLLOWING INSTRUCTIONS:

Transportation companies assume all liability from the time a shipment is received by them until the time it is delivered to the consumer. Our liability ceases at the time of shipment.

All shipments leaving our plant have been carefully inspected. If a shipment arrives with the crating or packaging damaged, have the carrier note the condition on the receipt. Check as soon as possible for concealed damage.

If it is found that the shipment has been damaged in transit, please **DO NOT** return it to us, but notify and file a claim with the carrier at once. **FAILURE TO FOLLOW THIS PROCEDURE WILL RESULT IN REFUSAL BY THE CARRIER TO HONOR ANY CLAIMS WITH A CONSEQUENT LOSS TO THE CONSUMER.**

If a UPS shipment has been damaged, retain the damaged material and the carton and notify us at once. WE will file a claim.

GOODS SHOULD NOT BE RETURNED FOR CREDIT UNLESS AUTHORIZED BY OUR SALES DEPARTMENT.

Case Drawings

Flangeless Built-In CW Series

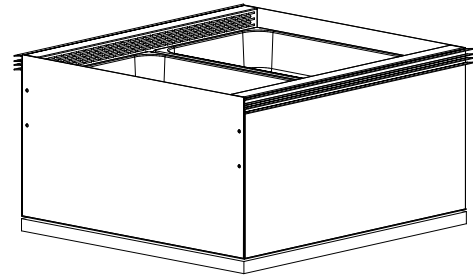
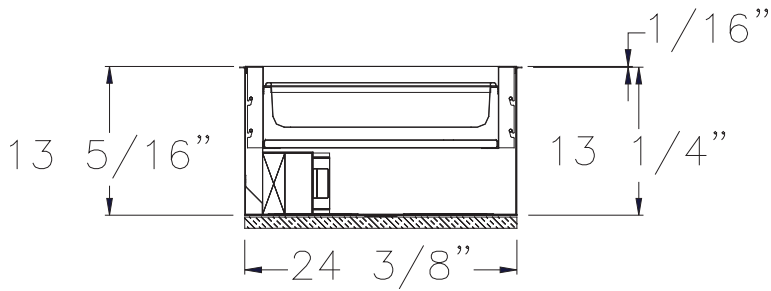

Flangeless Built-In CW-Angled Series

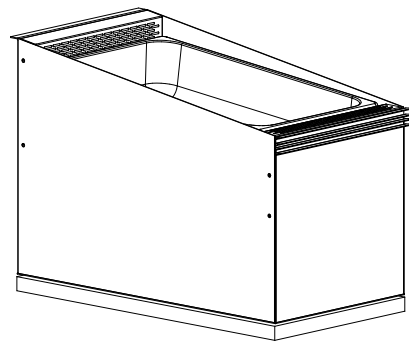
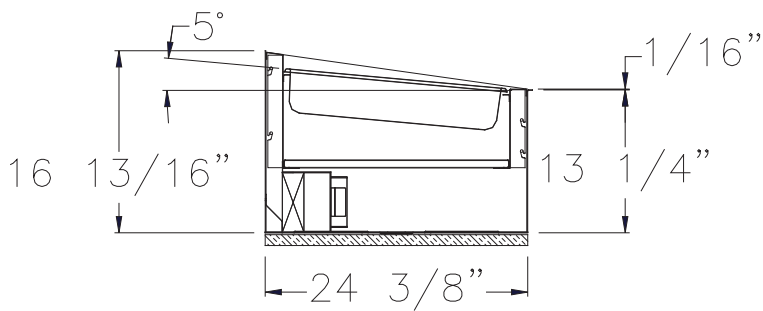

CW Drop-In Series

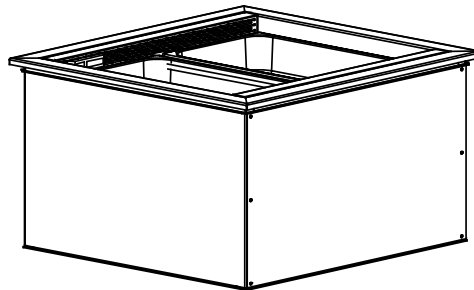
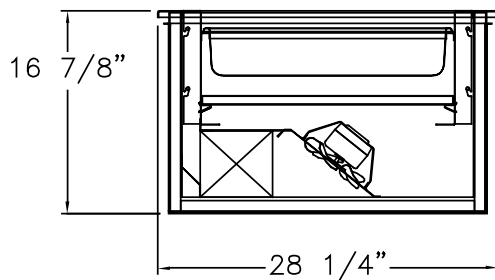

CW-Angled CW Drop-In Series

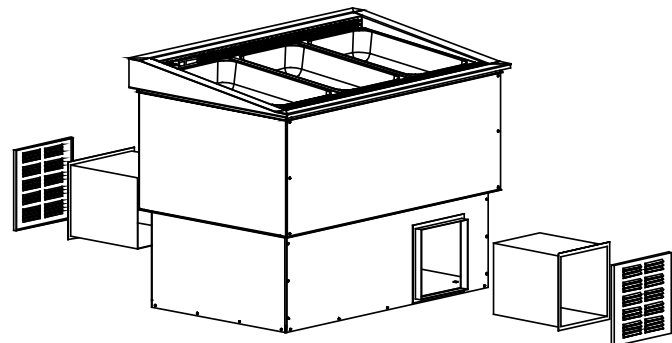
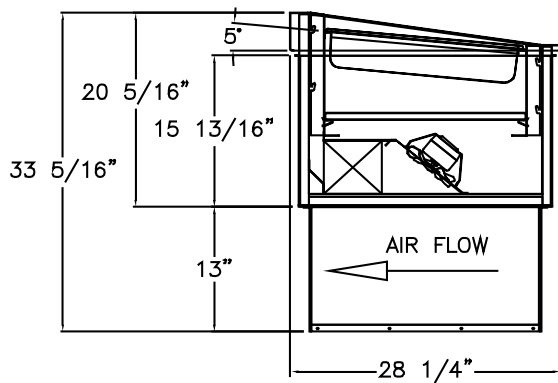

Case Drawings (continued)

CW Mechanical

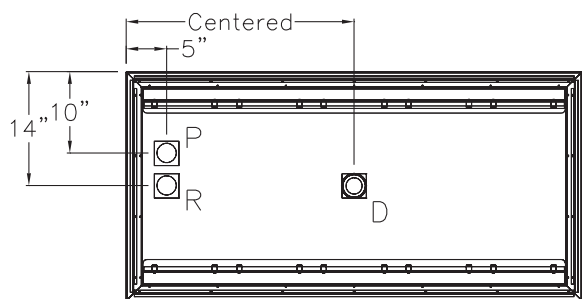

HW Series

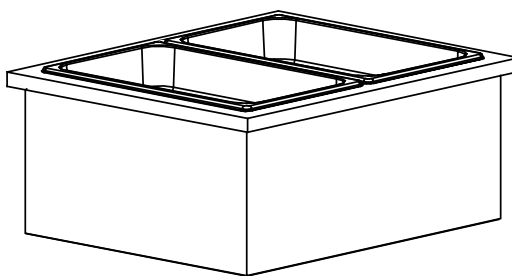
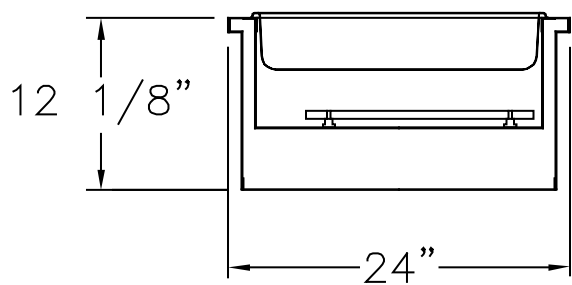

Installation Instructions

Location

This refrigerated display case has been designed for displaying and the storage of perishable food product. It is engineered for air-conditioned stores with a maximum ambient of 75° F and 50% relative humidity.

When selecting the location for placement of this case, avoid the following conditions:

Excessive air movement

- Doors
- Air-conditioned vents
- Other air sources

Excessive heat

- Windows
- Sun
- Flood lamps 8 feet or less from the product
- Other heat sources

Crate Removal

Move case as close as possible to its location. Remove all crating and shipping braces above the shipping pallet. Loosen the plastic dust cover from the pallet, but leave cover over the case to protect it while removing the case from the pallet. NOTE: Location of horizontal supports underneath of unit before removing from pallet, damage to the finished metal will occur if correct lift points are not identified prior to removal.



Case Exterior Loading

These cases are not designed for excessive external weight. **DO NOT WALK ON THE TOP OF THE CASES.** Walking on top of cases could cause personal injury and damage to the case.

Leveling

To ensure proper operation of the refrigeration system and drainage of the condensate, the case **MUST BE LEVEL.** Use a carpenter level to level front to back and side to side. Shim as necessary

Compressor

Self-Contained cases may be equipped with a shipping block under the compressor. This block must be removed upon installation. **FAILURE TO REMOVE THE BLOCK WILL RESULT IN EXCESSIVE NOISE, REFRIGERANT LEAKS AND WILL VOID WARRANTY PROTECTION.** Loosen all four nuts on the compressor hold down screws. Lift or pry the compressor up and remove the shipping block. **DO NOT** retighten screws, as the compressor should be left free to float on the spring mounts.

For proper refrigeration performance, **PRODUCT MUST NOT BE PLACED IN A POSITION WHERE IT MAY AFFECT THE AIR CURTAIN.**

Load Limits

DO NOT place product in merchandiser until all controls have been adjusted and are at the proper operating temperature. **DO NOT** overload product. **DO NOT** place product where it may affect the air curtain.

Drain, Electrical and Refrigeration Connections on Remote Cases

NOTE: Barker remote units are shipped with a dry nitrogen charge of approximately 10 lbs. pressure in the evaporator coil. During installation if nitrogen charge is not present, leak check accordingly

1. Connect the PVC drains (or the copper drains) to existing floor drains. Traps are shipped at the factory within the case. **ALL DRAINS MUST BE TRAPPED.** Provide as much downhill slope as possible and avoid long runs of drain lines. Do not install condensate drains in contact with non-insulated suction lines in order to prevent condensate from freezing.

2. Electrical connections are made through the power supply box of each case. Check the data tag located on the exterior of the case for voltage requirements and component amperage. **CASE MUST BE GROUNDED.**

3. Refrigeration connections are made through the refrigeration access cut out. See refrigeration information section of this manual for caseload and recommended settings. Refrigeration lines may be headed together for all cases in a lineup, if desired, by lines through the access area under the case. Refrigeration lines need to be connected in the lower refrigeration compartment or through the toe kick area.

Installation Instructions (continued)

Do not run lines through the evaporator coil area. ALL LINES MUST BE CORRECTLY SIZED. For proper refrigeration performance, PRODUCT MUST NOT BE PLACED IN A POSITION WHERE IT MAY AFFECT THE AIR CURTAIN. Air discharge and return air vents must remain unobstructed.

Glass Adjustment

The front lift glass on this case is installed at the factory with the case perfectly level. If adjustments need to be made to align the glass first check to insure the case was properly leveled during installation.

NOTE: THIS IS A 2-PERSON OPERATION. ONE PERSON MUST HOLD THE GLASS AT ALL TIMES.

1. Lift the glass to its highest position.
2. Loosen allen screws.
3. Slide glass right or left until the glass is even and is recessed into the aluminum extrusion.
4. Tighten the right allen screw while holding the left side of the glass firmly. Be careful to keep the glass level.
5. Tighten the remaining allen screws.
6. Lower glass into position. Repeat as necessary until glass is completely level.

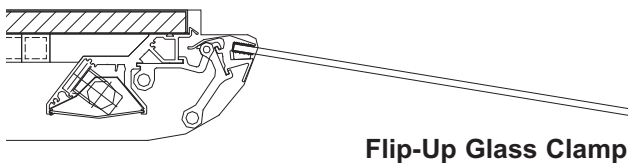

Flip-Up Glass Clamp

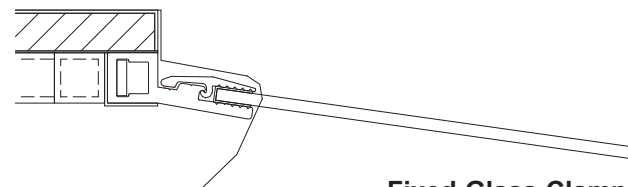

Fixed Glass Clamp

Cart Bumper Installation

Note: If merchandiser is ordered with cart bumper, step 1 & 2 are completed at the factory.

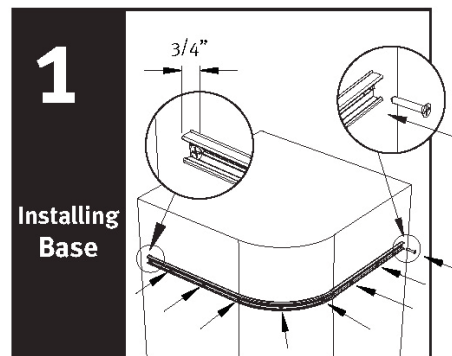

1
Installing Base

Cut plastic base to desired length of fixture. When using end caps be sure to cut base 3/4" short of fixture edge. When using corners, be sure to cut base so that it is flush with fixture edge. Secure base to fixture with screws every 4" on center. Make sure to put a screw 3/8" away from the cut end of base.

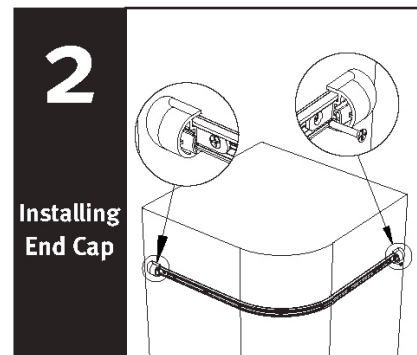

2
Installing End Cap

SNAP end caps or corners onto the base extrusion. Secure with #8 flat head phillips screws.

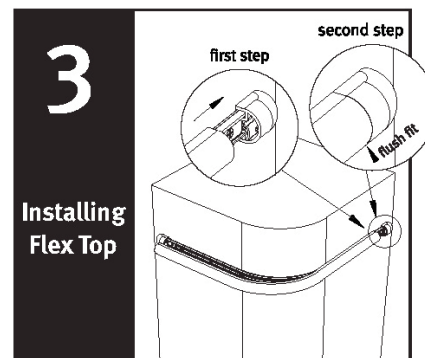

3
Installing Flex Top

When installing flexible bumper top, the cut ends need to be as straight as possible. To mount on a curved or flat surface, start at one end and attach bumper to base by hooking bumper top onto track, then snap bottom portion into place and slide bumper against the end cap for a flush fit. Continue to hook bumper onto base track with your hand or using a rubber mallet until you reach other end cap. NOTE: Cover mallet with a cloth to prevent marring the bumper finish.

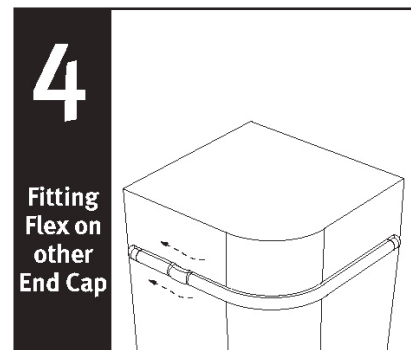

4
Fitting Flex on other End Cap

Installation Instructions (continued)

Mark and cut tail end of flexible bumper at least 1/8" longer than beyond the end cap position.

NOTE: Make sure the end cut is straight and square for proper fit. Slightly retract the bumper in order to feed cut end into the end cap as you finish hooking the top and bottom edges of the bumper onto the base track. You should feel and hear the bumper snap into place for a snug fit.

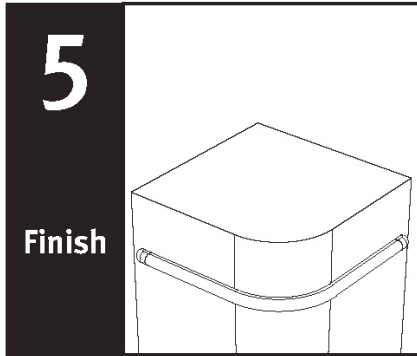

Finally, check for proper fit and attachment along the entire length of bumper which is either on the wall or a fixture. Make sure you have a smooth and flush fit against the end caps. NOTE: Clean any dust or debris with a cloth and non abrasive cleaner.

Helpful Hints:

- Set the uncoiled flexible vinyl at room temperature 24 hours prior to installation.
- Over cut the flexible vinyl and compression fit. Adding the additional material will compensate for stretching which occurs during installation.
- Use a clean, dry cloth and any mild household cleaner or soap solution; spray and wipe clean

Refrigeration Information

Cold Well Operation

Refrigeration

The refrigeration in this cold well is thermostatically controlled. The cold well refrigerates until the cut out point on the thermostat is reached. The thermostat opens, cutting power to the liquid line solenoid. The compressor continues to run, the system pumps down causing the pressure switch to open, cutting power to the compressor. NOTE: Some cases may be ordered with EPR valves to control case temperature. If equipped with an EPR valve, the compressor will run continuously.

Defrost

Cold wells have two different types of defrost; hot gas and off cycle. The hot gas defrost system is time initiated; temperature and time terminated. The defrost timer energizes the defrost solenoid and de-energizes the liquid line solenoid. When the temperature in the case reaches 40°, the defrost terminator thermostat de-energizes the hot gas solenoid. The system pumps down and the pressure switch cuts power to the compressor. The unit stays in off cycle defrost until the defrost timer re-energizes the liquid solenoid. NOTE: The evaporator fan runs continuously. On the Off Cycle defrost systems; the timer cuts the power to the liquid solenoid causing the compressor to pump down to the cut out point on the pressure switch. The unit stays in off cycle defrost until the defrost timer re-energizes the liquid solenoid. NOTE: The evaporator fan runs continuously.

Typical Component Settings

Thermostat cut out: 26°-28°, 3° differential

CRO valve 404A 75
 134A N/A

TXV: 10° Superheat

Pressure switch

404A Low - 20 lb/55 lb High - 350 lb
 134A Low - 7 lb/25 lb High - 225 lb

Refrigeration Loads

Model: CW	BTU: 300	Evap Temp: +18°	Off Cycle Defrost: 20"/4hr	Hot Gas Defrost: 10"/2hr
--------------	-------------	-----------------------	----------------------------------	--------------------------------

Electronic Thermostat

The electronic thermostat is located in the rear storage of the case, or behind the front toe kick if it is up against a wall. The thermostat is equipped with a liquid crystal display providing a constant readout of the sensed temperature.



NOTE: The LCD display will be blank during defrost. A touch keypad that allows the users to select the set point temperature, differential and the heating /cooling modes.

Programming Steps for the ETC, Electronic Temperature Control

All thermostats are pre-set and cycle checked at the factory.

STEP 1: Press the set key once to access the Fahrenheit/Celsius mode. The display will display either **F** degrees Fahrenheit or **C** for degrees Celsius. Press the **up** arrow or the **down** arrow so the display indicates **F**.

STEP 2: Press the set key again to gain access to the Set-point. The LCD will display the current Set-point and the **S1** will be blinking. Press the **up** arrow to increase or the **down** arrow to decrease the temperature setting.

STEP 3: Press the set key again to gain access to the differential. The LCD will display the current differential and the **DIF 1** will be blinking. This should be set at 2°F.

STEP 4: Press the set key again to gain access to the cooling or heating mode. The LCD will display the current mode. Press either the **up** arrow or the **down** arrow to set the display in the **C1**, cooling mode.

STEP 5: Press the set key once more and the programming is complete. Set the lock to keep the set point.

STEP	DISPLAY INDICATION	DESCRIPTION
1.	F or C	Fahrenheit or Celsius Scale
2.	S1 (blinking)	Set-point Temperature
3.	DIF (blinking)	Differential Temperature
4.	C1/H1	Cooling or Heating Mode

Electrical Information

Model	Evap Fans
CW SERIES	
CW-2	0.43
CW-3	0.43
CW-4	0.43
CW-5	0.86
CW-6	0.86

Model	Evap Fans
HW SERIES	
HW-2	NA
HW-3	NA
HW-4	NA
HW-5	NA
HW-6	NA

Additional Loads for Self-Contained Units						
HP	Voltage	404A RLA/LRA	134A RLA/LRA	Cond Fan	Heater	Notes
NA	NA	NA	NA	NA	NA	
1/5	120-1-60	4.2/27	2.9/19	0.56	5.0	
1/4	120-1-60	NA	3.9/25	0.56	5.0	
1/4	120-1-60	5.3/34.6	NA	0.56	5.0	
1/3	120-1-60	6.5/29	NA	0.72	5.0	

Model	Voltage	404A RLA/LRA	134A RLA/LRA	Cond Fan	Heater	Total Amps
NA	208-3-60	NA	NA	NA	NA	1.62
NA	208-3-60	NA	NA	NA	NA	3.24
NA	208-3-60	NA	NA	NA	NA	4.87
NA	208-3-60	NA	NA	NA	NA	6.5
NA	208-3-60	NA	NA	NA	NA	8.11

Wiring Color Code

Green -----Ground	Orange-----Thermostat
Black -----Hot	Orange-----Liquid Solenoid
White -----Neutral	Purple -----Hot Gas Defrost
Red -----208/220 Only	Purple -----Defrost Terminator
Brown -----Interlock System	Gray -----Light Switch
	Black/White Pressure Switch

Off Cycle Timer

Grasslin

1. White - Neutral
2. Black - Hot
3. Black -
4. Orange - Liquid Solenoid

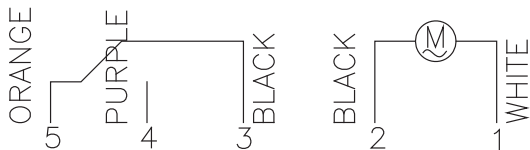

Parragon

4. Orange - Liquid Solenoid
- X. White - Neutral
- N. Black - Hot

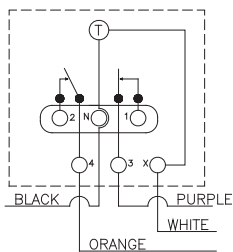

Hot Gas Timer

Grasslin

1. White - Neutral
2. Black - Hot
3. Black -
4. Purple - Hot Gas Defrost
5. Orange - Liquid Solenoid

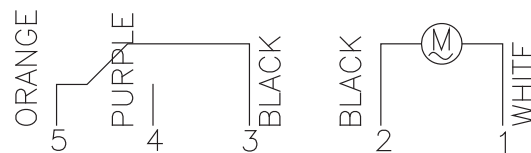

Parragon

- 1.
- 2.
3. Purple - Hot Gas Defrost
4. Orange - Liquid Solenoid
- X. White - Neutral
- N. Black - Hot

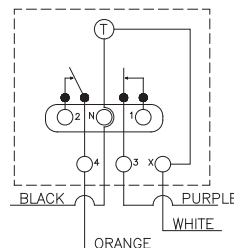

Electrical Information (continued)

Ballast Wiring

Red -----Lights
Yellow -----Lights
Blue-----Lights

SEE BALLAST DIAGRAM
FOR EACH CASE

NOTE: Case must be grounded

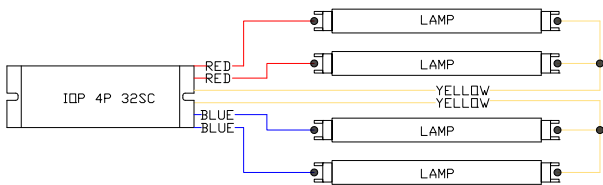
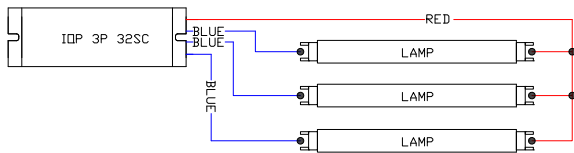
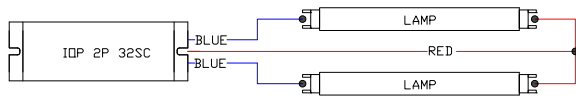

Hot Well Operation

Controls

The controls on this well are digital. To adjust, press the appropriate arrow firmly. There is one control per well.

The heating element turns on and off, once every second. The Heat Active dot blinks on and off each time the element is switched on and off and the dot is not blinking, (it is either always

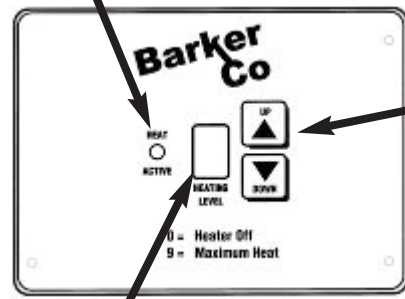

Adjust heating levels by pressing

This shows the heating level. Turn power on/off at the switch to the side
0=off
1=lowest
9=highest

Common Settings

Product that is immersed in liquid is easier to keep hot. Fried foods are the hardest to maintain temperature.

To adjust temperatures, change the setting, one number at a time. Allow 1-2 hours for the case temperature to even out before continuing.

The settings will need to be adjusted to your product format and store conditions. Use these settings as a starting point.

Once the correct setting is found, the controls may be left at that setting and turned off and on using the power switch on the main control. The case must be turned on 1½ hours before setting product.

Recommended settings are:	
Overhead controls	
5-6	
Fried foods	5-6
Immersed foods	

Unit Shutdown

Turn power off at switch. It is not necessary to adjust well controls. Remove product. Allow well to cool completely before cleaning.

Preheating

Turn on power switch. Let unit operate empty for 90 minutes before loading with product. Putting hot food in a case that has not reached full temperature will cause product temperature to drop quickly. All products must be preheated to 175°F. It is essential that product be fully cooked and heated prior to stocking the case. Check product temperature of larger pieces when cooking different size items. It takes longer for larger pieces to reach the desired temperature.

Temperature/Operation Guidelines

This merchandiser is designed to operate without water in the well. Adding water will cause the case to expend many BTU's heating the water and not the product.

Load Limits

Product must be contained to the tile or well area. Product must be placed in the center of the well.

Maintenance Information

Cleaning

Case Exterior

Clean surfaces frequently with warm water and mild detergent. DO NOT use strong alkali solutions, steel wool, or abrasive cleanser.

Air Plenum Removal

Remove deli pans. Pull air plenum up and out.

Bottom Shelf Removal

To remove bottom deck, use thumb holes to raise front and lift out towards you.

Evaporator Coil

Remove deli pans and bottom deck to access evaporator coil as shown. Clean as needed.

Condenser Coil

Clean condenser coil every three months or as needed with a whisk-broom or vacuum. DISCONNECT POWER WHEN SERVICING. FINS ON CONDENSER COIL ARE SHARP!

Condensate Heater

Add scale remover to condensate heater pan once every three months or as needed.

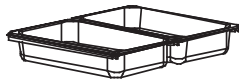
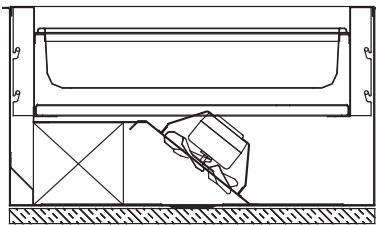

Deli

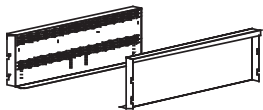

Air



Bottom

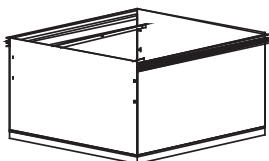

Well

Light Replacement

The fluorescent lights in this case are furnished with plastic safety shields and end caps. When replacing fluorescent lamps, be certain to reinstall safety shield and caps. (See illustration). If the bulb is not fully seated the lights will not operate. BE SURE BULBS ARE FULLY SEATED.

The light switch is mounted to the right side of the ceiling. See mechanical drawing for ballast box location.

A. To remove bulb, grasp lamp holder on either end of the bulb and with equal pressure pull down.

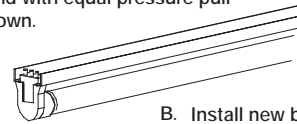

B. Install new bulb into the plastic safety tube protector. Insert bulb into end cap.

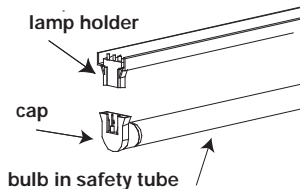

C. Position the bulb and cap under the lamp holder and with even pressure press the bulb into the light fixture.

Caution: Failure to install bulb fully into light socket will cause premature bulb life and may cause damage to light fixture

Service

WARNING!

DISCONNECT THE ELECTRICAL POWER WHEN SERVICING OR
REPLACING ANY

Preventative Maintenance

1. Read the Installation and Service manual.
2. See the trouble-shooting guide in the event of problems.
3. Contact Barker Company for an authorized service person in your area.

Trouble Shooting Guide For HW

Problem:	Action:
Unit fails to operate Main power light on Control is off.	Connect case to power supply. Reset circuit breaker. Unit may have two separate power sources. Check both sources.
No Heat Circuit breaker is off. Defective heating element. Loose wire or bad connection. Flashing indicator on control panel is blank or not flashing. Control has malfunctioned.	Check all power supply breaker. Reset circuit breaker. Contact Barker Specialty Service Department. Repair. Contact Barker Specialty Service Department. Contact Barker Specialty Service Department.
Inadequate Temperature Temperature is too low. Temperature is too high. Heating elements are not working.	Adjust controls (see recommended settings). Case must be preheated for 1 ½ hours prior to stocking. Product is not 175° before being placed in the case. Food that is below 175° internal temperature will cool quickly. Product is not placed in the center of the well or tile. Adjust controls, (<i>see recommended settings</i>). Product is stacked too high (within 6" of the overhead heating element). Contact Barker Specialty Service Department.

Service (continued)

Cold Well Troubleshooting Guide

Problem	Cause	Action
Case temperature is too warm.	<p>Case is in defrost.</p> <p>Product load may be over its limits blocking airflow.</p> <p>Ambient conditions may be affecting the case operation.</p> <p>Condensing coil or evaporator coil is clogged or dirty.</p>	<p>Review T-Stat settings.</p> <p>Redistribute product.</p> <p>Check case position in store. Is the case located near an open door, window, or air conditioning vent?. RH should not be over 50% and temperature above 75°.</p> <p>Clean coil.</p>
Case temperature is too cold.	<p>The T-Stat Temp is set too low.</p> <p>Ambient conditions may be affecting the case operation.</p> <p>Condensing coil or evaporator coil is clogged or dirty.</p>	<p>Check setting. See factory guidelines.</p> <p>Check case position in store. Is the case located near an open door, window, or air conditioning vent? RH should not be over 50% and temperature above 75°.</p> <p>Clean coil.</p>
Water has pooled under case.	<p>Case drain is clogged.</p> <p>Check PVC drains under case for leaks.</p> <p>Evaporator pan is overflowing.</p>	<p>Clear drain.</p> <p>Repair as needed.</p> <p>Check electrical supply to dissipater pan. Check float assembly. (Note: Cases equipped with electric dissipater pans should NEVER have food products washed or poured into the drain as it will result in damage to the heating element.)</p>
Frost or ice on evaporator coil.	<p>Check evaporator fans.</p> <p>Defrost clock doesn't work.</p>	<p>Check electrical connections. Have unit serviced by a qualified service technician.</p>

Hillphoenix Barker Specialty Products Service Department

IMPORTANT INFORMATION!

FOR PROMPT SERVICE WHEN CONTACTING THE FACTORY FOR SUPPORT, BE SURE TO HAVE CASE MODEL AND SERIAL NUMBER HANDY.

(THIS INFORMATION IS LOCATED ON THE DATA TAG ATTACHED TO THE CASE. SEE BELOW FOR DATA TAG LOCATIONS)

For any warranty or service issues not covered by this manual, for tech support, or for warranty service calls, please contact the Barker Specialty Products Service Department at:

(319) 293-3777

Parts

Ordering Procedure

1. Contact the Service Parts Department
Melissa Marshall
703 Franklin Street
PO Box 478
Keosauqua, IA 52565
Tel: 319-293-8323
Fax: 319-293-8377
melissa.marshall@hillphoenix.com
2. Provide the serial number of the case containing the part.
To locate the serial number look on the data tag located on the customer left, outside back of the case, the customer left, inside top of the case, or contact the factory for location.
3. If parts are to be returned for credit, contact the Parts Department. Do not send parts without authorization.



BEFORE SERVICING

**ALWAYS DISCONNECT ELECTRICAL
POWER AT THE MAIN DISCONNECT
WHEN SERVICING OR REPLACING
ANY ELECTRICAL COMPONENT.**

Hillphoenix®

A **DOVER**™ COMPANY

WARRANTY

HEREINAFTER REFERRED TO AS MANUFACTURER

FOURTEEN MONTH WARRANTY. MANUFACTURER'S PRODUCT IS WARRANTED TO FREE FROM DEFECTS IN MATERIAL AND WORKMANSHIP UNDER NORMAL USE AND MAINTENANCE FOR A PERIOD OF FOURTEEN MONTHS FROM THE DATE OF ORIGINAL SHIPMENT. A NEW OR REBUILT PART TO REPLACE ANY DEFECTIVE PART WILL BE PROVIDED WITHOUT CHARGE. PROVIDED THE DEFECTIVE PART IS RETURNED TO MANUFACTURER. THE REPLACEMENT PART ASSUMES THE UNUSED PORTION OF THE WARRANTY.

WARRANTY CLAIMS: All claims should include: the serial number of the cabinet, proof of purchase, date of installation, and all pertinent information supporting the existence of the alleged defect. Any action for breach of these warranty provisions must be commenced within one (1) year after that cause of action has accrued.

All warranty service work must be pre-authorized by Barker Specialty Products (800-814-0446). Barker Specialty Products reserves the rights to designate the service provider, time in which labor is to be performed and specify amount of time per warranty problem.

This warranty does not include labor or other costs incurred for repairing, removing, installing, shipping, servicing or handling of either defective parts or replacement parts.

The fourteen month warranty shall not apply:

1. To any unit or any part thereof which has been subject to accident, alteration, negligence, misuse or abuse, operation on improper voltage, or which has not been operated in accordance with the manufacturer's recommendation, or if the serial number of the unit has been altered, defaced, or removed.
2. When the unit, or any part thereof, is damaged by fire, flood, or other act of God.
3. Outside the continental United States.
4. To labor cost for replacement parts, or for freight, shipping expenses, sales tax or upgrading.
5. When the operation is impaired due to improper installation
6. When installation and startup forms are not properly complete or returned within two weeks after startup.

THIS PLAN DOES NOT COVER CONSEQUENTIAL DAMAGES. Manufacturer shall not be liable under any circumstances for any consequential damages, including loss of profit, additional labor cost, loss of any delay in its performance hereunder due to causes beyond its control. The foregoing shall constitute the sole and exclusive remedy of any purchases and the sole and exclusive liability of Manufacturer in connection with this product.

The Warranties are Expressly in Lieu of All Other Warranties, Express of Implied and All Other Obligations or Liabilities on Our Part. The Obligation to Repair or Replace Parts or Components Judged to be Defective in Material or Workmanship States Our Entire Liability Whether Based on Tort, Contract or Warranty. We Neither Assume Nor Authorize any Other Person to Assume for Us Any Other Liability in connection with Our Product.

Mail approved warranty claims to the address listed below:

Hillphoenix Barker Specialty Products
703 Franklin Street, PO Box 478
Keosauqua, IA 52565
Tel: 319-293-3777/Fax: 319-293-3776